

THE MANAGEMENT OF SPORTS SMART SERVICES SYSTEM IN COMPLETE RESIDENTIAL COMMUNITY IN HUNAN PROVINCE, CHINA

A GESTÃO DO SISTEMA DE SERVIÇOS ESPORTIVOS INTELIGENTES EM UM CONDOMÍNIO RESIDENCIAL NA PROVÍNCIA DE HUNAN, CHINA

Article received on: 11/10/2025

Article accepted on: 3/10/2026

Rongrong Hu*

*Suan Sunandha Rajabhat University, Bangkok, Thailand
s63484950032@ssru.ac.th

Supitr Samahito*

*Suan Sunandha Rajabhat University, Bangkok, Thailand
supits.sa@ssru.ac.th

The authors declare that there is no conflict of interest

Abstract

This study aims at the fitness needs of the complete residential community in Hunan, China, and reshaping the sports value of the complete residential community is a new requirement for the development of the new era. This paper mainly adopts mixed theory methodology design, quantitative and qualitative research, determine the theoretical research basis and research guiding ideology, the results process analysis, conclusion analysis process, mainly to complete community management, complete living community physical exercise conditions, sports wisdom service channel and satisfaction performance, using sociology from theoretical multidisciplinary, multi-angle to differentiate complete residential community sports smart service management research, demonstrates the study of seven hypothesis design research process. In order to improve the satisfaction of the community people in the field of sports public service and meet the needs of the public sports.

Keywords: China Hunan, Complete Residential Community, Community Sports, Sports Management.

Resumo

Este estudo tem como objetivo atender às necessidades de condicionamento físico de toda a comunidade residencial em Hunan, China, e redefinir o valor do esporte nessa comunidade é uma nova exigência para o desenvolvimento na nova era. Este artigo adota principalmente um desenho metodológico de teoria mista, com pesquisa quantitativa e qualitativa, para determinar a base teórica da pesquisa e a ideologia orientadora da pesquisa, o processo de análise dos resultados e o processo de análise das conclusões, focando principalmente na gestão da comunidade residencial, nas condições de prática de exercícios físicos na comunidade, nos canais de serviços esportivos inteligentes e no desempenho da satisfação. Utilizando a sociologia a partir de uma abordagem teórica multidisciplinar e multiangular, o estudo diferencia a pesquisa sobre gestão de serviços esportivos inteligentes na comunidade residencial e demonstra o processo de pesquisa com o desenho de sete hipóteses. A fim de melhorar a satisfação dos moradores da comunidade no campo dos serviços públicos esportivos e atender às necessidades do esporte público.

Palavras-chave: China-Hunan. Comunidade Residencial Integrada. Esportes Comunitários. Gestão Esportiva.



1 INTRODUCTION

As the housing system reform in the 1990s, China's domestic market economy transformation, land system reform and real estate development, all levels of commercial housing residents park district (complete community), high-grade villas, luxury residential park, economic applicable housing and other different types of residents park marketization degree suddenly, according to incomplete statistics China nearly 700000 complete residential community, nearly 20 000 complete residential community in Hunan province, the complete residential community construction development fast. Therefore, the domestic community research in China has gradually shifted to the research of complete residential community, from the relatively perfect research of community sports and family sports to the study of complete residential community sports in modern cities.

This paper explores the research of the application management of the smart service system of sports in complete residential community from the perspective of culture, environment and humanistic relations, which is to further improve the development of complete residential community sports in sports promoting the comprehensive development of people and social progress under the proposition of Chinese modernization, which is the focus of this research.

"Opinions on Strengthening the Collaborative Governance of Urban Residential Communities" is the first time for the central government to integrate the residential property management into the scope of social grassroots governance to promote the programmatic document. However, the practice of sports in Hunan Province is relatively weak, and the theoretical research on complete residential community is obviously lagging behind. In view of this, this study intends to start from the perspective of sports environment development, let the complete residential community residents understand from the concept of physical fitness will be a good way to change the physical health state, and form the value behavior of physical fitness from the knowledge related to sports, skills and understanding of sports.

2 RESEARCH OBJECTIVES

1. To Study and analyses the construction situation of the sports smart services system management in complete residential community in Hunan Province, China.

2. To develop the management of sports smart services system in complete residential community in Hunan Province, China.
3. To Accurately evaluating the satisfaction of residents in the smart system of sports services in complete residential communities in China.

3 LITERATURE REVIEW AND RELATED STUDIES

This study starts from the "Research on the Management of complete Residential Community sports smart Service System in Hunan Province, China", and studies the literature review and related studies, as follows;

1. Residential community management; The social development in China experienced a stage of urban housing (1949-1978), the stage of housing system reform (1988 to 1997), the process of housing commercialization (1998 to 2007) and the stage of urban housing (2008 to present). The concept is defined by 6 experts and scholars, and 7 people are on the topic of "complete residential community management". Finally, the concepts, theoretical definitions and statistical analysis of 24 complete residential communities were analyzed.
2. Fitness exercise conditions; Definition of the concept of "complete residential community fitness facilities" by 4 domestic experts and scholars: concept definition of "exercise prescription" by 6 experts and scholars; concept definition of "sports instructor" by 4 experts and scholars; and concept definition of "physical fitness monitoring system" by 7 experts and scholars. Finally, the concepts, theoretical definitions and statistical analysis of physical exercise conditions in 22 complete residential communities were analyzed.
3. Smart service channel; 4 domestic experts and scholars define the concept of "community smart sports platform"; 4 experts and scholars define the concept of sports station; and 4 experts and scholars define the concept of "smart sports service system". Finally, the relevant concepts, theoretical definitions and statistical analysis of 21 sports wisdom service channels are made.
4. Satisfaction performance; 11 domestic experts and scholars on related research on "evaluation index of public service governance"; 8 experts and scholars on "sports evaluation index"; and 13 experts and scholars on "evaluation of management service satisfaction". Finally, the concepts, theoretical definitions and statistical analysis of fitness

evaluation culture in 23 parks were analyzed. Literature research reference has reliability and importance, and data has certain research reference value.

5. Main types and experience summary of the complete residential community management mode in China; By reviewing a large number of domestic literature and analyzing it, Management mode of complete residential community in Shanghai; Wuhan Jiangnan; Shenzhen Lianhua North complete residential community management mode; Qingdao complete residential community management mode; Shenyang complete residential community management mode and so on the successful experience of the complete residential community management mode in China, The main successful experiences are as follows: first, to emphasize the community service function in the complete residential community management, Pay attention to the nature of the community service; Second, most of the complete residential community management in China adopts the multi-person integrated community management mode, Multi-person integrated management system and mechanism; Third, under the management concept of "small country, big society", The complete residential community should gradually promote the community autonomous management mode. At the same time, the main defects of the management mode of complete residential community in China are as follows: First, excessive emphasis on the public service function of complete residential community, Ignoring the cultural construction of the complete residential community; The second is to ignore the main status of the complete residential community, Too much emphasis on the role of the government; Third, the level of property management in the complete residential community is uneven, Has caused more complete residential community conflicts, Due to the lack of standardized and institutionalized management of the complete residential community property industry, Lack of corresponding supervision and management, The company is chaotic, Has caused more complete residential community conflicts, It has affected the harmonious and stable development of the complete urban residential communities.

4 RESEARCH METHODOLOGY

This study used a mixed-theory methodology design, qualitative research, and quantitative research.

1. **Research Design:** The analysis of the contents of the related research. The survey questionnaire was determined to fully understand the cultural environment of the complete residential community, and the current situation, predicament and causes of the sports development in the complete residential community.
2. **Population and Sample:** Investigation on the current situation of Wangfu Garden, Dexin Garden in Jishou City and Wujiang Tianjiao in Xiangtan City, Hunan Province.
3. **Instruments:** A random sample of 450 people was conducted to check the validity of the IOC (Project objective consistency Index) and the content of sports experts, managers, researchers and residents of complete residential communities. In-depth interviews with 10 experts and scholars clarified the key information of in-depth interviewees. When organizing the structured interviews, the researchers used a one-to-one interview process with a total of 10 participants. The tool used in the study was a focus expert panel discussion to test and confirm the impactiveness, applicability and feasibility of the evaluation of sports smart service system in complete residential communities in Hunan Province.
4. **Data collection:** Through the statistics and comparison of literature, works, papers and other related data, the collection and analysis of the data reports of the government community and the management industry affect the variables and proportion of the management of the sports smart service system of the complete residential community in Hunan Province. Analyze the standard sample difference of the complete residential community sports smart service system management in Hunan province.
5. **Data analysis:** Data analysis comes from theoretical concept research and literature analysis of related research papers; sample interview data analysis, using content analysis method; to sort out the development status of complete residential communities in China. Find out the development factors of sports smart service system management in the complete residential community in Hunan Province. For a further study.

Data analysis and statistics are mainly completed by SPSS data analysis, AMOS model setting structural equation analysis and other statistical analysis software.

4.1 Research scope

Figure 1

Research Framework

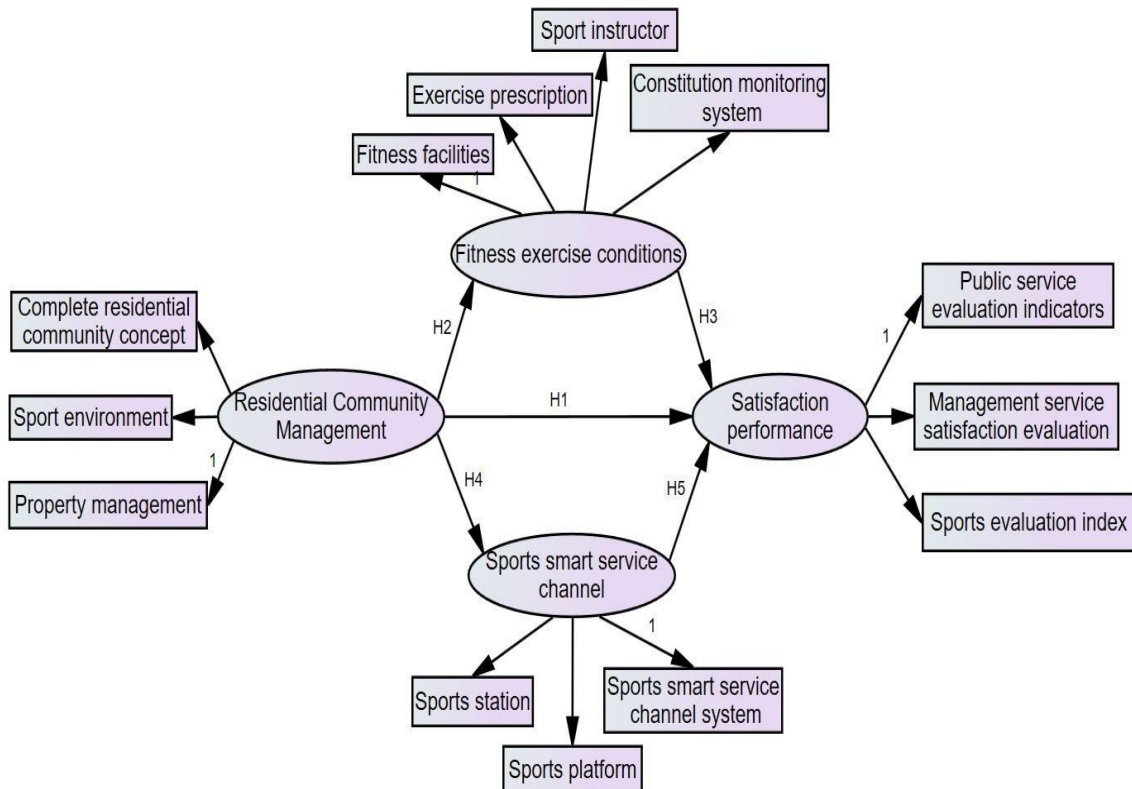

5 RESEARCH RESULTS

5.1 Determine the theoretical research basis and the guiding ideology of the research

1. Study the relevant research theories based on the management of the complete resident community sports smart service system. From this research, the research questions raised by the management of the complete resident community sports smart service system, the research purpose is set, and the research scope is established. According to the needs of research, five theoretical research guidelines and principles are set and established, such as community governance theory, good governance theory, participatory management theory, community self-organization theory and social capital theory, which determine the research

guidance direction for the later research.

2. Research scope and framework of the management of smart sports service system in complete residential communities in Hunan Province. Based on the study of complete residential community sports smart service system management in Hunan Province, China, this paper summarizes the complete residential community culture, residential community fitness exercise conditions, sports wisdom service channels, theoretical definition, statistical analysis and the main types of complete residential community management mode and experience in China, and constitutes the research scope and framework of the smart service system management of complete residential community sports in Hunan Province. details are as follows;

Figure 2

Framework diagram of the study content

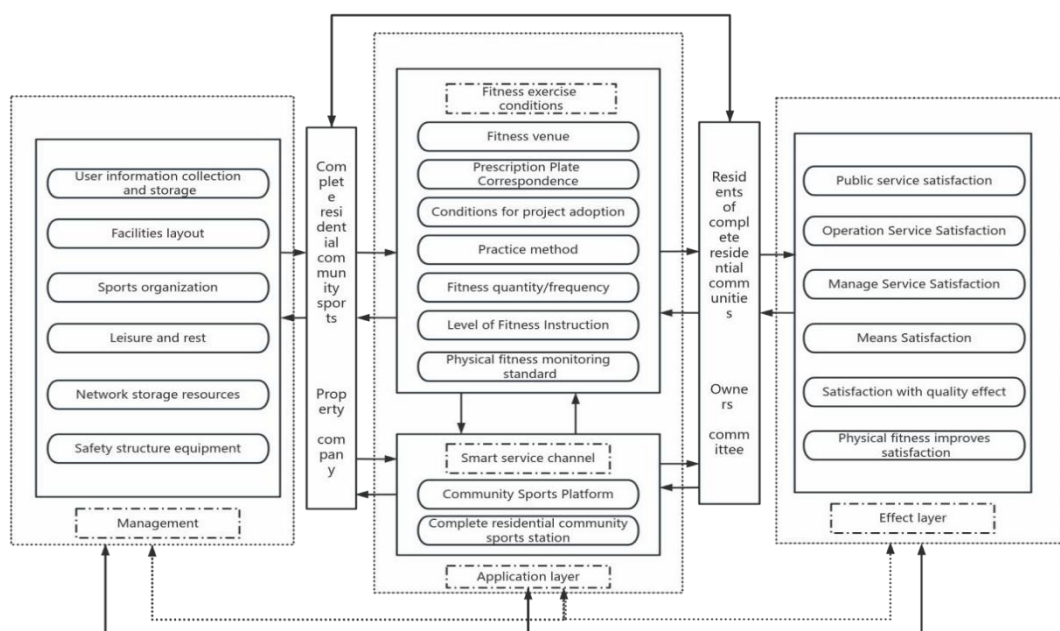
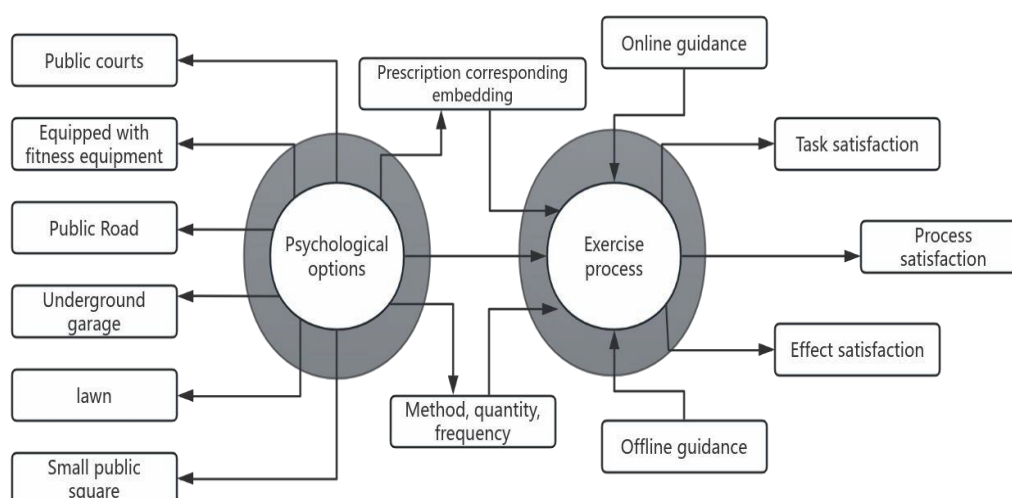

Figure 3*Study the structural framework*

3. Related research and hypotheses: Five guiding ideas and principles of theoretical research are set and established according to the needs of research, and seven main related hypotheses are set. The specific assumptions are as follows:

H1: The Residential community management has a positive and direct impact on Satisfaction performance

H2: The Residential community management has a positive and direct impact on Fitness exercise conditions.

H3: The Fitness exercise conditions have a positive and direct impact on the Satisfaction performance

H4: The Residential community management has a positive and direct impact on Smart service channel.

H5: The Smart service channel has a positive and direct impact on Satisfaction performance

H6: The impact of Fitness exercise conditions on Residential community management and Satisfaction performance plays a mediating role.

H7: The impact of Smart service channel on Residential community management and Satisfaction performance plays a mediating role.

5.2 The results of the qualitative analysis

5.2.1 Interview information collection and related research

Through semi-structured interview, we have built the basic information of government community management personnel, experts, community property managers and community public operators, and conducted extensive in-depth communication. This interview includes 11 questions of experts; 8 interviews of government community management; 12 interviews of community property management personnel and industry authority. At the same time, the complete influencing factors of the study of smart sports service management are collected: the influencing factors affecting the management of complete residential community; the factors affecting the fitness conditions; the influencing factors of smart service channels and the factors affecting the satisfaction of the use impact. In addition to the above factors, the recognition of quality impact satisfaction and physical improvement satisfaction is one of the important factors reflecting physical fitness, and obtains the recognition of the society and family. Physical fitness can enhance the trust of people in the residential community.

5.2.2 Qualitative focus group

The results of the analysis is mainly based on the theory is community governance theory, good governance, participatory management theory, community organization theory and social capital theory, according to the government community management, experts and scholars, community property management into three groups analysis discuss 17 complete residential community management, fitness conditions, smart service channels and use impact satisfaction related research issues, to complete residential community wisdom sports service management research purpose.

5.2.3 Qualitative analysis of the results

From the interview information collection and related research and the table 17 discussion questions can be seen that the study of the complete residential community wisdom sports service management of the latest survey information and research data analysis by the government community management, experts and scholars, community

property management of three groups of unanimous approval. The results of this qualitative study have certain interpretability, and the qualitative study has good reliability and validity, and has certain promotion value.

5.3 Descriptive Statistics for quantitative research

5.3.1 Quantitative research mainly combines the hypotheses of the previous study

The content reported by the researchers in this chapter is the result of data processing. The researchers mainly processed the data as follows: first, descriptive statistics based on the basic information of the scale ors; second, exploratory factor analysis (EFA) is used for primary component analysis (PCA) on scale data; finally, confirmation factor analysis (CFA) was performed on the scale data and a structural equation model (SEM) was constructed to assume and verify the path coefficients between each latent variable. Draw the correlation line between the independent variables and substitute the data into AMOS23 to get the following results:

Figure 4

The Structural Equation Model Diagram

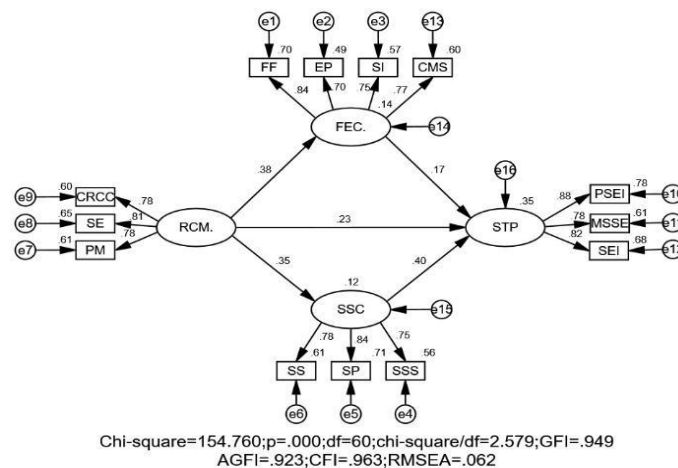

From the analysis of the reliability and validity of the full model validation of the structural equation described above, we can see that the designed Cale has good reliability, consistency, stability and validity.

5.3.2 The fit of the model

From Table 1, it can be seen that all indicators of the model meet the standards referenced by McDonald, Hair, and other research, indicating that the model has a good fit.

Table 1

Fit analysis of the entire model

Fit indices	Figure	Reference standards	Standard source
χ^2/df	2.579	<5	McDonald(2002)
GFI	0.949	>0.8	McDonald(2002)
AGFI	0.923	>0.8	McDonald(2002)
SRMR	0.079	<0.08	Hu & Bentler(1999)
RMSEA	0.062	<0.08	McDonald & Ho (2002)
NFI	0.941	>0.9	Fornell & Larcker (1981)
CFI	0.963	>0.9	Fornell & Larcker (1981)
IFI	0.963	>0.9	Fornell & Larcker (1981)

5.3.3 Hypothesis testing results

Table 2 shows the hypothesis results that directly affect the entire model. H1: RCM can have a significant positive impact on STP (B=0.252, t=3.87). H2: RCM can have a significant positive impact on FEC (B=0.417, t=6.42). H3: FEC can have a significant positive impact on STP (B=0.165, t=3.11). H4: RCM can have a significant positive impact on SSC (B=0.355, t=5.73). H5: SSC can have a significant positive impact on STP (B=0.428, t=7.02).

Table 3*Hypothesis test results for direct impacts of the entire model*

Path	Relationship	Path coefficient	SE	t-value	Result
H1:RCM→STP	+	0.252***	0.065	3.87	Support
H2:RCM→FEC	+	0.417***	0.065	6.42	Support
H3:FEC→STP	+	0.165**	0.053	3.11	Support
H4:RCM→SSC	+	0.355***	0.062	5.73	Support
H5:SSC→STP	+	0.428***	0.061	7.02	Support

Note: ** is significant at the 0.01 level (2-tailed); *** is significant at the 0.001 level (2-tailed)

As shown in Table 3, in the test results for the significance of the mediating impacts of RCM -->FEC -->STP and RCM -->SSC -->STP, it is assumed that the standardized path coefficient of H6 (RCM -->FEC--> STP) is 0.069, Bias-corrected percentile is [0.020, 0.144], indicating that the hypothesis of H6 is valid. Assuming that the standardized path coefficient of H7 (RCM -->SSC -->STP) is 0.152, Bias-corrected percentile is [0.089, 0.244], it indicates that the hypothesis of H7 is valid.

Table 4*Hypothesis test results for indirect impacts of the entire model*

Path	Relationship	Path coefficient	LLC-ULCI	Result
<u>H6:RCM</u> →FEC→STP	+	0.069**	[0.020,0.144]	Support
<u>H7:RCM</u> →SSC→STP	+	0.152***	[0.089,0.244]	Support

Note: ** is significant at the 0.01 level (2-tailed); *** is significant at the 0.001 level (2-tailed)

6 DISCUSSION

This study is mainly based on the "five" related theoretical research and related policy and system management analysis conclusions. The qualitative research is mainly analyzed by the government community management, experts and scholars, and community property management. Descriptive statistics, exploratory and confirmatory factor analysis, and correlation analyses were performed from 450 validated

questionnaires. From the quantitative study method constructed structural equations ted analyzing the data collected using Excel, SPSS, AMOS, and other software analysis model modeling the data. Finally, the following conclusion is drawn:

6.1 The residential community management has a positive and direct impact on Satisfaction performance

According to the theoretical research of "community governance theory" and the conclusion of related policy and system management, only the decentralization between the government organization and the complete resident community autonomous organization can ensure that the complete resident community organization become an independent power subject. The main body of community governance is the autonomous organization of the property company and the owners committee. The government community plays the service role in the management, and the property company and the owners committee manage and make decisions on the community affairs. Theoretically, the complete residential community management has a positive and direct impact on the satisfaction performance.

The qualitative analysis results show: that the complete residential community sports service market in Hunan province will be in an important position in the future, determining and affecting the health of the complete residential community people, and playing a vital role in promoting the development of cities in Hunan Province.

From the quantitative analysis-model results: according to the results of positive direct influencing factors and reliability analysis, the main methods of measuring reliability using impact satisfaction include semi-reliability and kronbach's alpha coefficient. The latent variables were tested for linear tests, further indicating that there may be higher intermediate latent variables among these three first-order latent variables. Confirmation the fitting inde of the factor analysis (CFA) scale measurement model, convergence validity, discriminatory validity.

6.2 The residential community management has a positive and direct impact on Fitness exercise conditions.

From in accordance with the theory of "good governance" research and related policy system management research conclusion: due to the particularity of Chinese complete residential community governance system, so Chinese urban complete residential community essentially has the nature of "autonomy", community is not only a legal autonomy community, also have basic administrative community management functions and provide sports public service platform, is the government community and complete residential community people of social community.

The qualitative analysis results show : that the quality of physical fitness covers the way of prescription plate correspondence and project adoption and the quality and efficiency of physical fitness is unexpected. Community people are eager to see the results of sports and fitness quality efficiency and increase the participation of community people.

6.3 The fitness exercise conditions have a positive and direct impact on the satisfaction performance

From in accordance with the "community self-organization theory" theory and related policy system management research conclusion: the comprehensive factors affecting residents fitness activities, is systematically determine the fitness facilities, fitness ecological environment, fitness comprehensive management and fitness sports culture atmosphere is the fitness environment, improve complete living community fitness exercise conditions to use impact satisfaction performance.

The qualitative analysis shows that the reliability and consistency of physical fitness is the basis for the property managers to establish the trust of the complete residential community, and the enhancement of the awareness of democratic participation of the complete residential community is the main driving force to promote the development of the community.

From the quantitative analysis-model results: the researchers conducted an exploratory factor analysis on 52 measurement questions and extracted a fixed factor using principal component analysis, indicating that the scale data collected by the researchers had no significant impact on the general method bias. Confirmation factor analysis (CFA) scale measurement model of fitting inde, mainly from the convergence

validity, discriminatory validity. Therefore, each impact satisfaction has good discriminative validity.

6.4 The residential community management has a positive and direct impact on Smart service channel

From the theoretical research of "participatory management theory" and the research conclusion of related policy and system management: through the power operation of sports smart service system management, jointly promote and share the whole process of residential community sports environment. Theoretically, the complete residential community management has a positive and direct impact on the sports smart service channel.

The qualitative analysis results show that sports social media, traditional media and official websites provide the attraction of physical fitness to the people in the complete residential community. Complete accommodation community sports station can maintain the consistency of all aspects of sports fitness through the design of community sports station, which can form a stronger exercise prescription impact. Community smart sports service channels can more impactively convey the information related to them, and improve the participation of the community people.

From the quantitative analysis-model results, the questionnaire used in this study meets the requirements of content validity. Using a common method bias tests, this suggests that scale data collected by researchers has no significant impact on general method bias. Confirmation factor analysis (CFA) scale measurement model of fitting index, mainly from the convergence validity, discriminatory validity.

6.5 The smart service channel has a positive and direct impact on Satisfaction performance

From in accordance with the theory of "social capital" theory of research and related policy system management research conclusion: social capital is the state of the connection between subjects and its characteristics, for the community, the main role of social capital is to maintain the stability of the community and action relative consistency,

enhance the community of identity, so as to improve the efficiency of community individuals or system. Theoretically, the smart service channel has a positive and direct impact on the satisfaction performance.

From the qualitative analysis results show that: smart service channel main content is the construction of community wisdom sports service website, to build new fitness facilities, improve its recognition and trust in the community people's mind, increase the complete residential community outdoor fitness equipment, organize sports activities, through the online public pilot way, can success also reflects the property management organization ability and management level.

From the quantitative analysis-model results, the questionnaire used in this study meets the requirements of content validity. Using a common method bias tests, this suggests that scale data collected by researchers has no significant impact on general method bias. Confirmation factor analysis (CFA) scale measurement model of fitting index, mainly from the convergence validity, discriminatory validity. Therefore, each impact satisfaction has good discriminative validity.

6.6 The impact of fitness exercise conditions on residential community management and Satisfaction performance plays a mediating role.

According to the theory of "community governance theory" and "community self-organization theory" and related policy and system management research conclusion: by determining the scope of government community responsibility and exercising the way of management power, implement more efficient community management. Specifically, the implementation in the complete residential community needs to rely on certain organizational forms to realize the expression and decision-making of the people in the complete residential community, and finally realize the Chinese social management pattern of "social coordination and public participation" at the level of the complete residential community.

From the qualitative analysis results show that: through various channels and means to provide the community, people use choose way or follow, determine the sports, exercise duration, exercise intensity to scientific choice way, in real life for professional

exercise prescription guidance, through impactful comprehensive sports science communication, promote the sports service channel construction and development.

From the quantitative analysis-model results: using the common method bias test, the researchers conducted exploratory factor analysis on 52 measurement questions, and extracted a fixed factor using principal component analysis, which indicates that the scale data collected by the researchers had no significant impact on the bias of the general method. Confirmation factor analysis (CFA) scale measurement model of fitting inde, mainly from the convergence validity, discriminatory validity.

6.7 The impact of smart service channel on residential community management and satisfaction performance plays a mediating role.

From in accordance with the theory of "social capital" and "community governance theory" theory research and related policy system management conclusion: the main role of social capital is to maintain the stability of community and action relative consistency, enhance the community identity, wisdom sports its core is combined, improve the quality of the sports service, optimize the user's sports experience, promote the innovation of sports management, and optimize the use of sports resources.

From the qualitative analysis results show that: as the core content of sports service channel, the interests of sports service channel of the community trust determines their recognition and support of sports prescription, it can impactively promote sports prescription in the social market brand use and development, optimize the complete residential community sports service supply and management, enhance the initiative of complete residential community sports service, creativity and precision.

From the quantitative analysis- -model results, the fitting inde of the confirmation factor analysis (CFA) scale measurement model is mainly derived from the convergence validity and discriminatory validity. Therefore, each residential community management and use impact satisfaction scale has a good discriminative impactiveness. Finally, the fit of the model to the results of the hypothesis test directly affects the hypothesis test and the hypothesis test of the mediation impact, which indicates that the hypothesis of H7 is valid.

7 CONCLUSION

7.1 Strengthen the construction of policies, funds, and hardware equipment support system for complete sports services in residential communities

Build community sports service supply "basic clothing complex" and "diversified service complex", build sports health as the core of the new area "community sports combination-exercise body" mode, further promote the development of community sports service quality and multi-level coverage, rich complete residents community sports service supply side, realizing a complete coverage of diversified supply side.

7.2 Broaden the overall role of integrated sports service in practice

It is of great significance to establish and consolidate the core position of the complete residential community sports embedded mode in the community home physical exercise service, and to consolidate and strengthen the overall function of the practice mode in the complete residential community sports service.

7.3 Establish a complete third-party information integration and service support platform for residential community sports services

It is an important way to improve the implementation impact of complete community sports service to gradually establish the cooperative mechanism of property department leading, resource sharing, balance of interests and efficient cooperation, and gradually reduce the cooperative obstacles, which is of great significance for the optimization of the practice mode of complete community sports service in the future.

7.4 Improve the professional level of sports services in the complete residential community

Vigorously promote and advocate residents to participate in physical exercise, community form a good actively participate in physical exercise, make some professional

knowledge or engaged in related professional work residents to participate in community sports service, regular professional community sports service personnel training, encourage sports service professionals and organizations within the improvement of the professional level.

7.5 Improve the quality of complete residents and community residents to meet the requirements of community sports development

Residents' health should adapt to the requirements of community sports development, improve their sports operation ability, and adapt to the modern social life and sports mode through continuous learning. Therefore, residents actively improve their lifelong sports awareness and the level of sports science and culture, and become an important subject in the management of community sports.

8 RECOMMENDATIONS

8.1 Optimize regional layout and balance quantity distribution

According to the characteristics of the complete residential community sports in Hunan Province. For some living areas with weak economic development in western Hunan, we will encourage the construction of smart community sports and the construction of basic fitness facilities of community sports. Secondly, the inspection and communication of smart community fitness among various residential areas in Hunan province can be carried out to develop in a comprehensive and balanced way.

8.2 Accelerate the process of wisdom and link information and data

The information platform of community sports in Hunan Province also lacks personalized and customized management services for community residents. It can introduce or combine with Keep and other fitness application functions to analyze the accuracy of community residents during fitness exercise, create online and offline exercise methods, and speed up the smart process of community sports.

8.3 Strengthen the dynamic cooperation mechanism of the optimization, refining and promotion of services

In the study of Hunan province should break the existing system policy barriers and practice barriers, realize the optimization function of community sports service mode in Hunan province, actively build community sports service third-party support system in Hunan province, improve the ability of community sports service supply in Hunan province need to optimize and service mode platform, promote the development of community sports service in Hunan province.

FUNDING

The research is supported by: Hunan Province social Science Fund Study on sports service path of health promotion for the elderly in Hunan community

REFERENCES

- Chen, A., & Chen, C. (2001). *Sports dictionary*. Shanghai Lexicography Publishing House.
- China Labor and Social Security Press. (2008). *Occupational classification of the People's Republic of China*. China Labor and Social Security Press.
- Gong, L.-J., Gao, D., Chen, X.-K., & Wang, X.-T. (2022). Research hotspots, development trends and implications of global exercise prescription: Based on CiteSpace V. *Journal of Beijing Sport University*, 21–33.
- Guo, Y. (2017). Research on the construction of urban fitness places from the perspective of environmental aesthetics. *Journal of Physical Education and Sports*, 24(4), 45–50.
- Han, X., & Jiang, C. (2009). Establishment of mathematical model of logical method of physical fitness monitoring data in 2005. *Science of Sports and Sports*, 29(3), 90–94.
- Huang, J., Cao, J., & Huang, Y. (2019). Research on the construction of public sports service guarantee system in healthy urban communities under the background of "Healthy China." *Journal of Xi'an Physical Education University*, 36(3), 295–299.
- Lu, X. (2022). *Study on exercise prescription in Alzheimer's disease based on deep learning* [Master's thesis, Xihua University].

- Mei, Y. (2021). *Research on influencing factors and improving countermeasures of national fitness public service satisfaction* [Master's thesis, Shanghai University of Physical Education].
- Nie, C. (2020). On the legal concept of "environment": From the evolution of environmental thought. *Legal Science*, 1–6.
- People's Republic of China. (n.d.). *Property management regulations*. <https://www.gov.cn/zhengce>
- Physical Education and Sports Commission of the Central People's Government. (1993, December 4). *Technical hierarchy of social sports instructors*.
- Shi, X., & Dai, J. (2018). Construction and empirical research of performance structure model of national fitness public service in the new era: Based on measurement of "people-centered" value orientation. *Sports Science*, 38(3), 12–26.
- Song, J., & Sun, Q. (2005). Construction of evaluation system of urban community sports fitness environment. *China Sports Science and Technology*, 2005(4), 99–102.
- Song, T., & Huang, J. (2022). Research on post-use evaluation of urban sports park based on audience satisfaction perspective. *Journal of Shenyang Institute of Physical Education*, 41(1), 76–82.
- State General Administration of Sport. (2011, October 9). *Measures for the administration of social sports instructors*. State General Administration of Sport.
- Sun, J. (2021). *Research on evaluation index system construction and application of mainstream sports fitness guidance APP in China* [Master's thesis, Shanxi Normal University].
- Tian, T., & Wang, Y. (1996). On fitness environment. *Science of Sports and Sports*, 1996(6), 47.
- Wang, C., He, M., & Zeng, W. (2021). Research on new infrastructure enabling high-quality development of public sports services in China. *Sports Culture Guide*, 2021(1), 69–74.
- Wang, J., Wang, H., Wang, W., & Liu, X. (2020). Design and planning of fitness environment for residential and community sports. *Architectural Skills*, 2020(5), 48–53.
- Wang, W. (2004). *Exercise prescription*. Guangdong People's Publishing House.
- Wang, X. (2011). *Exercise prescription theory of traditional Chinese medicine and its treatment case study* [Doctoral dissertation, Beijing Sport University].
- Wu, H. (2021). *Research on the design of fitness facilities in urban parks* [Master's thesis, Donghua University].

- Yang, F. (2018). Research on construction and development planning of smart sports in Wuhan. *Hubei Sports Science and Technology*, 37(4), 305–338.
- Yang, Z. (2003). Several legal issues in property management. *Journal of Hebei Radio and Television University*, 2003(2), 29–31.
- Ye, Q., & Wei, N. (2010). The inevitable trend of smart sports informatization. *Journal of Nanjing University of Physical Education*, 10(9), 117–119.
- Zhang, Y., Jiang, C., Cai, R., & Qiu, S. (2012). Establishment and application of national physical fitness monitoring quality control system. *Shandong Sports Science and Technology*, 34(4), 87–91.

Authors' Contribution

All authors contributed equally to the development of this article.

Data availability

All datasets relevant to this study's findings are fully available within the article.

How to cite this article (APA)

Hu, R., & Samahito, S. (2026). THE MANAGEMENT OF SPORTS SMART SERVICES SYSTEM IN COMPLETE RESIDENTIAL COMMUNITY IN HUNAN PROVINCE, CHINA. *Veredas Do Direito*, 23(6), e235871. <https://doi.org/10.18623/rvd.v23.5871>