

## EFFECT OF DISTAL SEARCH, TECHNOLOGICAL TURBULENCE AND SOLUTION PROVISION COMPETENCE ON SOLUTION PERFORMANCE IN PHARMACEUTICAL SERVICES IN THAILAND

### *EFEITO DA BUSCA DISTAL, DA TURBULÊNCIA TECNOLÓGICA E DA COMPETÊNCIA NA PROVISÃO DE SOLUÇÕES NO DESEMPENHO DAS SOLUÇÕES EM SERVIÇOS FARMACÊUTICOS NA TAILÂNDIA*

Article received on: 11/27/2025

Article accepted on: 2/26/2026

**Chayanan Kerdpitak\***

\*Suan Sunandha Rajabhat University, Tailândia

Orcid: <https://orcid.org/0000-0002-7127-0353>

[chayanan.ke@ssru.ac.th](mailto:chayanan.ke@ssru.ac.th)

**Napassorn Kerdpitak\***

\*Suan Sunandha Rajabhat University, Tailândia

[napassorn.ke@ssru.ac.th](mailto:napassorn.ke@ssru.ac.th)

The authors declare that there is no conflict of interest

#### **Abstract**

It cannot be denied that with time, the intensive and extensive knowledge of information plays a critical role in improving business performance. It is an important process for business service organizations to highlight the role of information sharing and knowledge. The given study has the significant and primary aim is to consider the impact of distal search on the solution performance of the firms while the mediating role of provision competence and the moderating role of technological turbulence. The self-administrated survey questionnaire designed and distributed among the employees and service organization people in Thailand. The survey questionnaire is designed based on measures and scales which is ensured by the managers and employees working in the organization. At the same time, different tests are also applied such as descriptive analysis for approaching the mean, median and standard value. A KMO and SEM test is also applied to check the acceptance or rejection of the hypothesis. The results and tables have indicated that the distal search and solution provision competence has a positive and significant impact on the performance of the companies in terms of finding and evaluating the different solutions. At the same time, the role of technological turbulence is also emerging in this regard. Thus, overall the technological solution helps in fulfilling the customer needs along with the firm value.

#### **Resumo**

*Não se pode negar que, com o tempo, o conhecimento intensivo e extensivo da informação desempenha um papel fundamental na melhoria do desempenho empresarial. É um processo importante para as organizações de serviços empresariais destacar o papel do compartilhamento de informações e do conhecimento. O presente estudo tem como objetivo principal e significativo analisar o impacto da pesquisa distal no desempenho das soluções das empresas, considerando o papel mediador da competência de prestação de serviços e o papel moderador da turbulência tecnológica. O questionário de pesquisa autoaplicável foi elaborado e distribuído entre os funcionários e o pessoal de organizações de serviços na Tailândia. O questionário foi elaborado com base em medidas e escalas validadas pelos gerentes e funcionários que trabalham na organização. Ao mesmo tempo, também foram aplicados diferentes testes, como a análise descritiva para estimar a média, a mediana e o desvio padrão. Um teste KMO e SEM também foi aplicado para verificar a aceitação ou rejeição da hipótese. Os resultados e as tabelas indicaram que a busca distal e a competência de provisão de soluções têm um impacto positivo e significativo no desempenho das empresas em termos de encontrar e avaliar as diferentes soluções. Ao mesmo tempo, o papel da turbulência tecnológica também está se destacando nesse sentido. Assim, de modo geral, a solução tecnológica ajuda a atender às*



**Keywords:** Distal Search. Solution Performance. Solution Provision Competence. Technological Turbulence.

*necessidades do cliente, juntamente com o valor da empresa.*

**Palavras-chave:** *Busca Distal. Desempenho Da Solução. Competência De Provisão De Soluções. Turbulência Tecnológica.*

## 1 INTRODUCTION

Globalization has deemed necessary for the firms to keep track of the needs and wants of customer more frequently and rapidly as more innovation and customer solution is desired by them (Cabigiosu & Campagnolo. 2019; Heirati & Siahtiri. 2019). For this purpose. it is necessary that they are well acquainted with the knowledge from their internal and external environments and the technological changes to have the compatibility and competency of providing solutions to customers for their business needs.

**Table 1**

*Technological transformation in Thailand (ASEAN Post)*

<b>Traditional way</b>	Smart farming
<b>Traditional way</b>	Valuable services
<b>Buy technology</b>	Make technology

For this purpose. distal search has to be actively implemented by the firms so that they can design more flexible programs to assist and serve the customers to control the technological turbulence. which is characterized by life cycle of product as short and challenging structure of market in which entry and exit is frequent with a loss of revenue and changing customer expectations (Belderbos. Faems. Leten. & Looy. 2010; Wilden & Gudergan. 2015; Wu. Wan. & Levinthal. 2014; Zhou & Wu. 2010). So. the change in technological environment creates an ambiguity in the environment (Chae. 2012; Didonet. Simmons. Díaz-Villavicencio. & Palmer. 2012; Troilo. De Luca. & Atuahene-Gima. 2014) which if not handled effectively can negatively impact the service and solution performance of firms.

## Graph 1

*Companies share in Pharma market of Thailand*

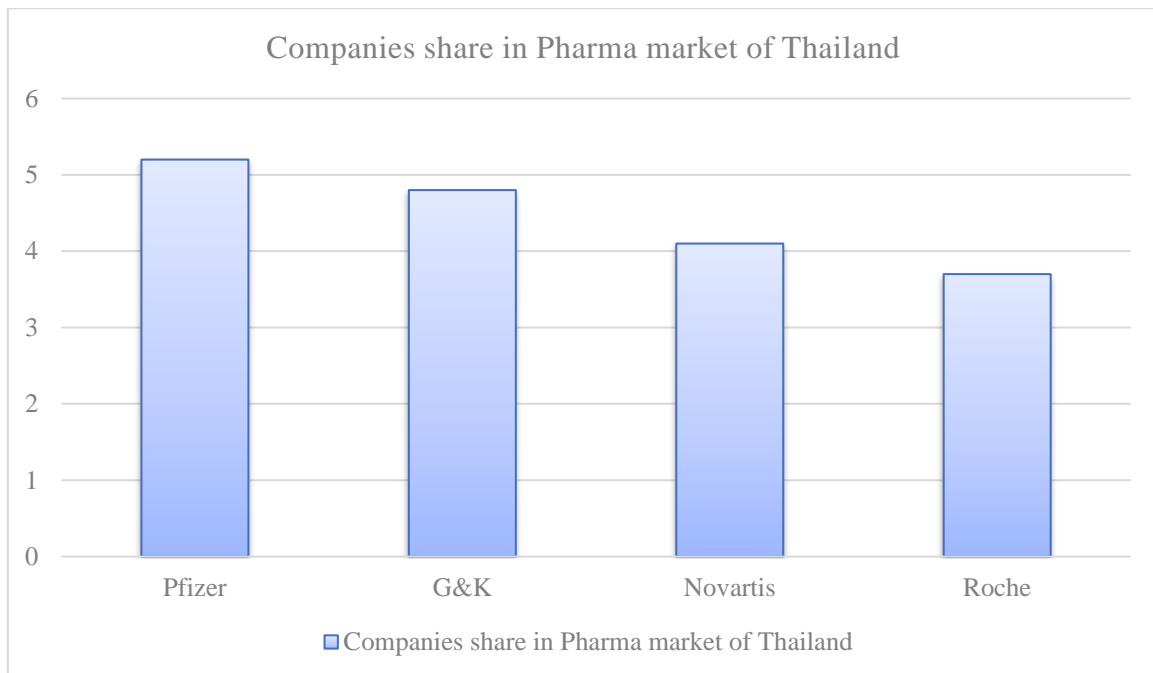

Previous scholars have worked on these variables (Chen & Lin. 2009; Storey & Kahn. 2010; Zahra, Neubaum. & Larrañeta. 2007). however the research is limited and needs to be expanded by further investigation through involving more factors affecting non- financial performance (Aarikka-Stenroos & Jaakkola. 2012; Siahtiri. 2018; Siahtiri. Heirati. & O'Cass. 2020; Storey & Larbig. 2018). Also the impact of technology on how knowledge firms perform is recommended (Celtekligil & Adiguzel. 2019). This study covers these research gaps. Hence. this study has research objectives which are outlined as follows:

- To investigate the impact of Distal search on Solution Performance
- To investigate the impact of Solution provision competence mediating the association of Distal search and Solution Performance
- To investigate the impact of technological turbulence moderating the association of Distal search and Solution Performance

The main scope for this paper is to explore how Distal search influences solution performance in the pharmaceutical services in Thailand and how Solution provision competence serves as a mediator and technological turbulence as a moderator in these

relationships. Theoretically, this study adds contribution to the RBV theory and the literature of these variables by investigating the underlying mechanism by examining the effect of Solution provision competence as a mediator and the boundary constraint mechanism, by investigating the effect of technological turbulence as a moderator in these associations. Practically, this study has implications for firms which aim to achieve the desired service performance by employing the distal search for attaining competency for providing solutions in the pharmaceutical industry.

The structure of the current paper is as given ahead. In the first section, Introduction is given highlighting the research objectives and questions with problem statement. Further, the next section gives the review of literature in detail. Next, research methodology to get answers to research questions will be laid down. The results will be presented next with the discussion on them. Finally, conclusion will be drawn, while pin pointing the research limitations and highlighting the research implications.

## **2 LITERATURE REVIEW AND THEORETICAL BACKGROUND**

Based on “The Resource-based view (RBV)”, which states that firms utilize resources so as to achieve the desired organizational performance, this study implies that knowledge is a resource of the organization which can contribute to building the capability of solution provision to achieve the desired solution performance.

### **2.1 Impact of distal search**

Search of knowledge is important for the firms, especially knowledge based firms so that they can provide efficient solutions for complex issues of business to serve its customers uniquely (Celtekliligil & Adiguzel, 2019; Siahtiri, 2018; Siahtiri et al., 2020; Storey & Larbig, 2018). Distal search is the search taken to explore ideas and knowledge that goes ahead of the firm’s actual domain”. Solution performance can be defined as a combination of processes that allow the knowledge based firms to identify the actual customer problems and to design tailored solutions for addressing those problems while providing effective customer support (Atuahene-Gima & Wei, 2011; Schilling & Green, 2011) and is measured as to “the extent to which solutions solve business customer’s

problems”. Studies show that distal search is directly linked to solution performance (Siahtiri et al., 2020). Hence, the study can hypothesize:

*Hypothesis 1: Distal search has significant association with Solution Performance*

## **2.2 Mediation of solution provision competency**

Engaging in distal search can strengthen the ability of firm in developing the competency to define customer problems and designing effective customer solutions and providing solutions to their problems (Amonini, McColl-Kennedy, Soutar, & Sweeney, 2010; Casidy & Nyadzayo, 2019; Katila & Ahuja, 2002; Lichtenthaler, 2009). The SPC performs crucial tasks like engaging customers through eliminating and reducing the relational distance that exists between the customer and the firm. This step can strengthen the understanding shared between the client and the firm. Secondly, the SP competency helps change the knowledge and its search mechanism into the desired output which is the solution to the customer problems (Jiang, Yang, Pei, & Wang, 2016; Powers, Sheng, & Li, 2016; Siahtiri, 2017). The distal search is directly linked to the SPC (Siahtiri et al., 2020). So, this study can investigate the SPC as playing a mediating variable role in this relationship and can hypothesize:

*Hypothesis 2: Solution Provision Competence significantly mediates the relationship of Distal Search and Solution Performance*

## **2.3 Moderation of technological turbulence**

The development in IT in terms of direction and speed is the concept of TT (Celtekligil & Adiguzel, 2019). Also, the change in use of IT which a firm uses to operate in conditions in which new products are developed using technology to offer further opportunities in the industry (Celtekligil & Adiguzel, 2019). In the presence of technology turbulence, it becomes more viable for the search to be effective and diverse. Only then, this knowledge from the environment can serve to gain competency for solving the customer's problems (Pratono, 2018; Siahtiri, 2018; Srivastava, Iyer, & Rawwas, 2017). This implies that addressing to the technological changes can actually boost the

level of firm's service performance (Celtekliligil & Adiguzel. 2019; Hung & Chou. 2013; Su. Peng. Shen. & Xiao. 2013). So, this study can investigate the technological turbulence as moderating the linkage of distal search and the solution performance and can hypothesize:

*Hypothesis 3: Technological Turbulence significantly moderates the relationship of Distal Search and Solution Performance*

## Figure 1

*Research framework*

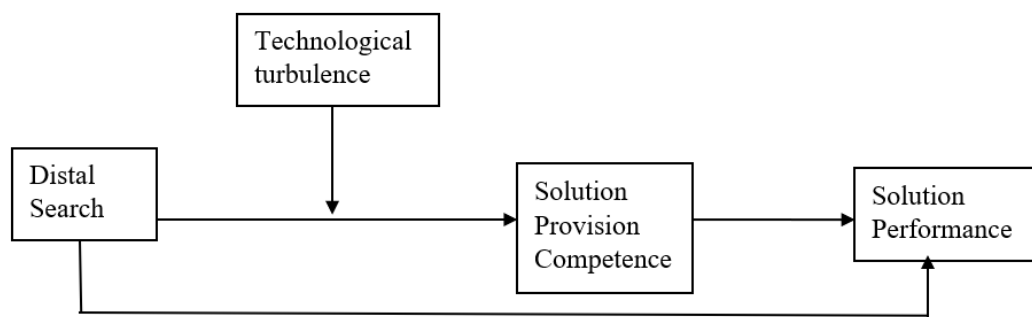

## 3 METHODOLOGY

### 3.1 Sample characteristics

The method of referral sampling was used to locate senior managers and supervisors belonging to pharmaceutical services sector of Thailand. The research implemented a questionnaire base survey method. Self-administered paper and pencil questionnaires were used to record responses and the respondent anonymity was ensured. That is why the names of organizations have been omitted from the study. The criteria of ten responses against each item, as set by the item response theory, was used to finalize the total number of respondents or sample size. In accordance with this phenomenon the researcher should have set a sample of 260 people.  $26 \times 10 = 260$ .

### **3.2 Measures**

The constructs were developed after significant literature review was conducted. The scales that have been included have been verified by a number of studies. All of the scale items had significant reliability and validity scores in previous studies. The validity and relevance of the scale items were ensured by pretesting the questionnaire on managers and academicians and then were made according to their feedbacks. Campbell, Brislin, Stewart, and Werner (1970) proposed the forward and back translation method. In accordance with the directions, by Brislin and company, the questionnaire was first formulated in English and then translated into Thai. Three different linguists were contacted to oversee the translation and two academicians were consulted to review the context of the questions. A five point Likert scale was used to measure and record responses.

### **3.3 Distal search**

Distal search was measured on the basis of a four item scale developed by Troilo et al. (2014). The scale was adapted according to the requirements of the present study. A sample item includes “Our firm searches and uses proven ideas and methods that we can adequately implement to ensure productivity”

### **3.4 Technological turbulence**

The scale for measuring technological turbulence was developed by Jaworski and Kohli (1993). It measured the technological change arising within an industry. A sample item includes “A large number of new product ideas have been made possible through technological breakthrough in our industry”.

### **3.5 Solution provision competence**

SPC was measured on the basis of the scale developed by Siahtiri et al. (2020). The scale was divided into four subscales; “problem definition. solution design. deployment. post-deployment customer support”. These dimensions were incorporated to correctly measure the competencies of the solution provider networks. The scale had a total of 12 items. A sample item includes “Our firm has systems. processes. and people dedicated to co-designing new solution(s) aimed at solving the specific problem(s) that best fit the customers’ internal and external conditions”. “Our firm has systems. processes. and people dedicated to providing continuing customer collaboration and support to undertake corrective action(s) in relation to deployed solution”.

### **3.6 Solution performance**

Solution performance was measured according to the scale developed by Siahtiri et al. (2020). The scale was adapted according to the requirements of the study. The scale consists of three items. A sample item includes “Our firm has performed well relative to our standards in delivering solutions that were exactly what customers want”.

## **4 RESULTS**

### **4.1 Demographics**

A total of 260 employees belonging to the pharmaceutical services sectors of Thailand were contacted for the purpose of this survey. Out of these 52.1 percent of the respondents identified themselves as male and 47.9 percent identified as females. The disparity is observed because more men are interested in IT and the survey was directed at the IT professionals working in the pharmaceutical services sector. The educational level of 77.8 percent of the respondents was equivalent to masters and the age 59.8 percent was between 31 and 50. The elevation is observed because senior managers and supervisors were taken as respondents.

## 4.2 Descriptive analysis

The skewness values depict normality of the data. as the values are less than -1 and therefore within the prescribed limit of +1-1. The mean values are approaching 4. showing the agreement of the respondents with the statements of the constructs. However. outliers were found in the observations recorded for TechTub. all other responses are devoid of outliers.

**Table 1**

### *Descriptive Statistics*

	N	Minimum	Maximum	Mean	Standard Deviation	Skewness	Std. Error
TechTub	11	3.00	4.90	4.97904	0.875	-.909	.38
DisServ	11	3.00	5.00	5.06299	0.844	-.749	.38
SolPerf	11	3.00	5.00	5.06113	0.775	-.872	.38
SolPerCm	11	3.00	5.00	5.04891	0.723	-.684	.38
Valid N (listwise)	11						

## 4.3 KMO

KMO is used to determine the adequacy of the sample and sample size. A value nearing 1 assures the sample is adequate and can be forwarded for SEM and other tests and analysis. The sphericity is also significant which is an indication. that no relevance exists between the constructs.

**Table 2**

### *KMO and Bartlett's Test*

Kaiser-Meyer-Olkin Measure of Sampling Adequacy.	.939
Bartlett's Test of Sphericity	94.87385
df	32
	5

Sig. 0 .00

---

#### 4.4 Factor loading

The individual construct items are significant and contribute in the overall variance of the construct. The values of all individual items is greater than 0.7 and the issue of cross-loading isn't present as well.

**Table 3**

*Rotated Component Matrix<sup>a</sup>*

	Component			
	1	2	3	4
TT1		.711		
TT2		.789		
TT3		.847		
TT4		.869		
TT5		.843		
TT6		.845		
TT7		.835		
DS1			.822	
DS2			.857	
DS3			.866	
DS4			.850	
SP1				.827
SP2				.856
SP3				.886
PC1	.852			
PC2	.870			
PC3	.877			
PC4	.905			
PC5	.898			
PC6	.893			

PC7	.871
PC8	.846
PC9	.856
PC10	.858
PC11	.826
PC12	.853

#### 4.5 Convergent and discriminant validity

Construct validity has two subtypes convergent and discriminant validity (Hassan. Hameed. Basheer. & Ali. 2020; Iqbal & Hameed. 2020). CV is determined on the basis of higher values of AVE and CR. MSV is less than AVE and the diagonal formed at the right hand side of table 4 depicts the presence of convergent and discriminant validity.

**Table 4**

*Convergent and Discriminant Validity*

	CR	AVE	MSV	MaxR(H)	DS	TT	SP	PC
DS	0.941	0.801	0.331	0.943	<b>0.895</b>			
TT	0.952	0.739	0.331	0.974	0.575	<b>0.860</b>		
SP	0.928	0.811	0.315	0.981	0.561	0.478	<b>0.900</b>	
PC	0.926	0.773	0.207	0.990	0.315	0.455	0.386	<b>0.879</b>

#### 4.6 Model fitness

CFA test is used to declare the fitness of the model. The test measures the model fitness on the basis of CMIN, RMSEA, GFI, IFI and CFI values. As table 5 showcases, all 5 measures are in accordance with the defined thresholds therefore the model is deemed fit.

**Table 5**

Confirmatory Factors Analysis

Indicators	Threshold range	Current values
CMIN/DF	Less or equal 3	2.166
GFI	Equal or greater .80	.870
CFI	Equal or greater .90	.964
IFI	Equal or greater .90	.963

RMSEA Less or equal .08 .061

**Figure 1**  
CFA

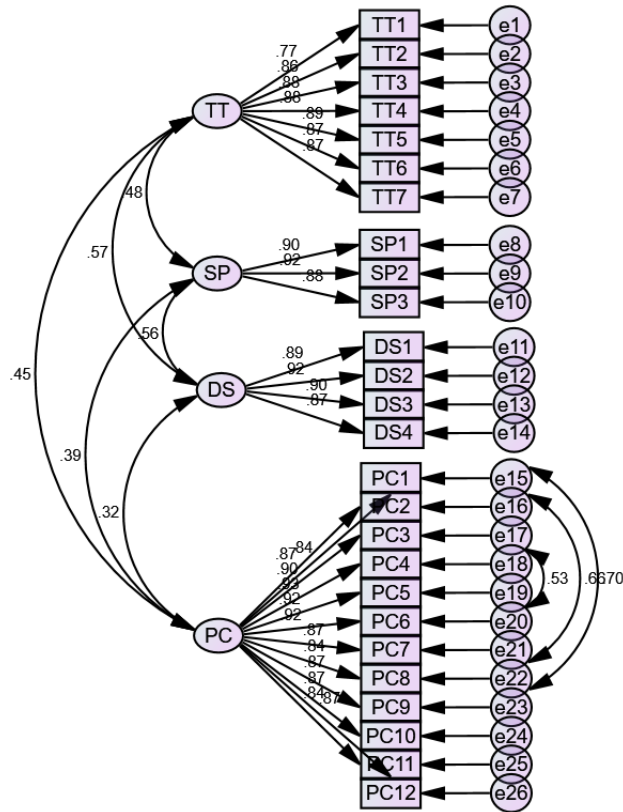

**4.7 SEM**

A unitary increase in Disserv produces a change of 49.1 percent in SolPerf. The relationship is significant and the hypothesis is accepted. A unit change in SolPerCm produces a change of 22.3 percent in SolPerf. The relationship is significant. however it acts as a mediator in this study. The mediating effect of SolPerCm between DisServ and SolPerf produces a change of 6.7 percent. The hypothesis is accepted as the relationship is significant. Graph 1 demonstrates the effects of moderation of TechTurb. The moderation effects are also significant therefore the hypothesis is accepted.

**Table 6***Structural Equation Modeling*

Total Effect	DisServ	SolPerCm
SolPerCm	.300***	.000
SolPerf	.558***	.223**
Direct Effect	DisServ	SolPerCm
SolPerCm	.300***	.000
SolPerf	.491***	.223**
Indirect Effect	DisServ	SolPerCm
SolPerCm	.000	.000
SolPerf	.067**	.000

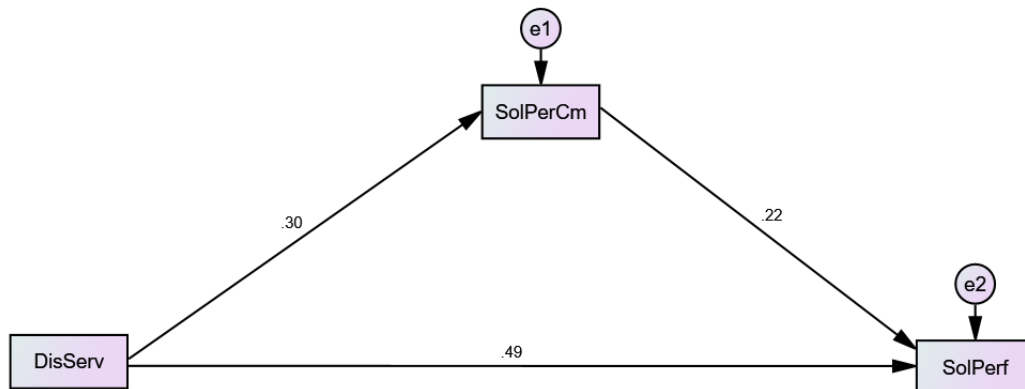
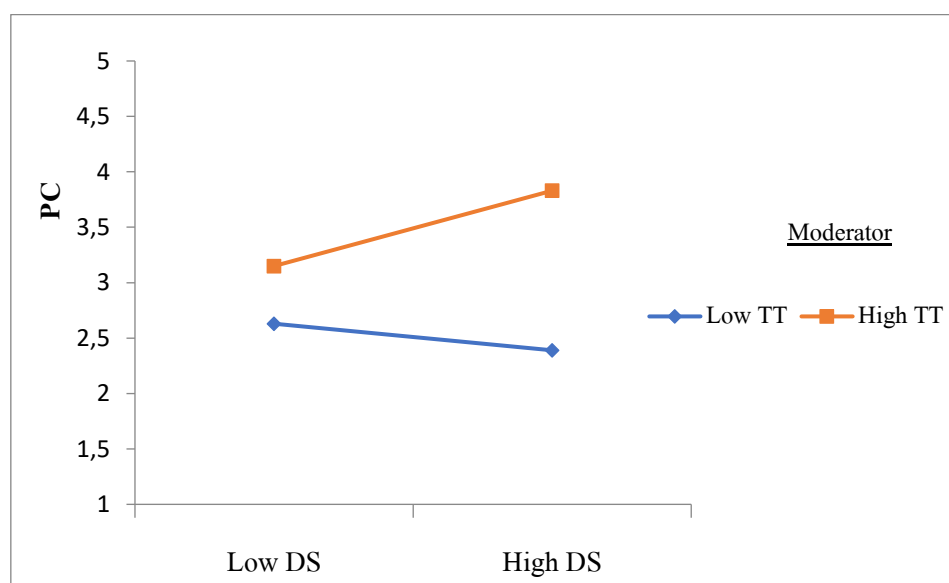
**Figure 2***SEM***Graph 1***Moderation*

## 4.8 Discussion

Wentrup and Ström (2019) Argued that business service markets (BSM) are more competitive and a significant issue for companies and sectors that incorporates knowledge-intensive business service or KIBS. The primary and initial results of the study indicate that the role of distal search is significant in enhancing the solution performances of pharmaceutical services in Thailand. This is because the distal search system can serve and provide effective solutions to consumers with some unique and complex problems related to business; hence the first hypothesis of the study has been accepted (Haissaguerre et al., 2019). The measurements of the results also indicate that solution provision competence has a positive impact on the solution performance of the pharmaceutical services of Thailand. The positive impact of SP is also manifest by the Siahtiri et al. (2020) solution provision competence is an organizational level competence factor that facilitates the process of solutions provided by the company and sometimes customers gain benefits from this ability of the sector. This is the main reason that this hypothesis of the study has been accepted.

## 5. CONCLUSION

The main objective of the following research is to evaluate how the knowledge-intensive pharmaceutical services (KIPS) address the challenge of BSM. mainly by examining how solution provision competence or SPC contributes to the provision of significant solutions and suggestions. The study also aims to examine the moderating impact of technological turbulence to find some further solutions and suggestions. In this research study, most of the information is collected mainly from the 311 employees of the pharmaceutical services of Thailand in which 162 were male and 149 were females. The following research study also used some appropriate techniques and methods to compute results such as rotated component matrix, SEM and KMO.

### Implications and Limitations

The findings and results of this research study will be very helpful for the managers of KIPS firms in Thailand that need to ensure a high level of strategic flexibility

and other significant factors. The results of the given research study also help the KIPS organizations of Thailand to understand the concept as well as the moderating impact of technological turbulence. The findings of this research also provide a significant platform for fellow researchers to use their results to get wider results in the future.

The following study has many limitations such as evaluation is limited and restricted to the business units in medium to large organizations in Thailand. Therefore, future research should focus on this issue and also include other business units. Second, the given research mainly relies on the employee's judgments, so, it is recommended to future studies that they should consider other individuals of KIPS firms in Thailand.

## REFERENCES

- Aarikka-Stenroos, L., & Jaakkola, E. (2012). Value co-creation in knowledge intensive business services: A dyadic perspective on the joint problem solving process. *Industrial Marketing Management*, 41(1), 15-26.
- Amonini, C., McColl-Kennedy, J. R., Soutar, G. N., & Sweeney, J. C. (2010). How professional service firms compete in the market: an exploratory study. *Journal of Marketing Management*, 26(1-2), 28-55.
- Atuahene-Gima, K., & Wei, Y. (2011). The vital role of problem-solving competence in new product success. *Journal of Product Innovation Management*, 28(1), 81-98.
- Belderbos, R., Faems, D., Leten, B., & Looy, B. V. (2010). Technological activities and their impact on the financial performance of the firm: Exploitation and exploration within and between firms. *Journal of Product Innovation Management*, 27(6), 869-882.
- Cabigiosu, A., & Campagnolo, D. (2019). Innovation and growth in KIBS: the role of clients' collaboration and service customisation. *Industry and Innovation*, 26(5), 592-618.
- Campbell, D., Brislin, R., Stewart, V., & Werner, O. (1970). Back-translation and other translation techniques in cross-cultural research. *International Journal of Psychology*, 30, 681-692.
- Casidy, R., & Nyadzayo, M. (2019). Drivers and outcomes of relationship quality with professional service firms: An SME owner-manager perspective. *Industrial Marketing Management*, 78, 27-42.

- Celtekligil, K.. & Adiguzel, Z. (2019). Analysis of The Effect of Innovation Strategy and Technological Turbulence on Competitive Capabilities and Organizational Innovativeness in Technology Firms. *Procedia Computer Science*. 158. 772-780.
- Chae, B. (2012). A framework for new solution development: an adaptive search perspective. *The Service Industries Journal*. 32(1). 127-149.
- Chen, H.-J.. & Lin, T.-C. (2009). Exploring source of the variety in organizational innovation adoption issues—An empirical study of managers' label on knowledge management project issues in Taiwan. *Expert Systems with Applications*. 36(2). 1380-1390.
- Didonet, S.. Simmons, G.. Díaz-Villavicencio, G.. & Palmer, M. (2012). Firms with capability to leverage substantial technological resources to come up innovation. *Marketing Intelligence & Planning*. 30(7). 757-779.
- Haissaguerre, M.. Cheniti, G.. Escande, W.. Zhao, A.. Hocini, M.. & Bernus, O. (2019). Idiopathic ventricular fibrillation with repetitive activity inducible within the distal Purkinje system. *Heart rhythm*. 16(8). 1268-1272.
- Hassan, S. G.. Hameed, W. U.. Basheer, M. F.. & Ali, J. (2020). Zakat Compliance Intention Among Self-Employed People: Evidence From Punjab, Pakistan. *Al-Adwah*. 34(2). 80-96.
- Heirati, N.. & Siahtiri, V. (2019). Driving service innovativeness via collaboration with customers and suppliers: Evidence from business-to-business services. *Industrial Marketing Management*. 78. 6-16.
- Hung, K.-P.. & Chou, C. (2013). The impact of open innovation on firm performance: The moderating effects of internal R&D and environmental turbulence. *Technovation*. 33(10-11). 368-380.
- Iqbal, J.. & Hameed, W. U. (2020). Open Innovation Challenges and Competition-Based Open-Innovation Empirical Evidence From Malaysia *Innovative Management and Business Practices in Asia* (pp. 144-166): IGI Global.
- Jaworski, B. J.. & Kohli, A. K. (1993). Market orientation: antecedents and consequences. *Journal of marketing*. 57(3). 53-70.
- Jiang, X.. Yang, Y.. Pei, Y.-L.. & Wang, G. (2016). Entrepreneurial orientation, strategic alliances, and firm performance: Inside the black box. *Long Range Planning*. 49(1). 103-116.
- Katila, R.. & Ahuja, G. (2002). Something old, something new: A longitudinal study of search behavior and new product introduction. *Academy of management Journal*. 45(6). 1183-1194.

- Lichtenthaler. U. (2009). Outbound open innovation and its effect on firm performance: examining environmental influences. *R&d Management*. 39(4). 317-330.
- Powers. T. L., Sheng. S., & Li. J. J. (2016). Provider and relational determinants of customer solution performance. *Industrial Marketing Management*. 56. 14-23.
- Pratono. A. H. (2018). Does firm performance increase with risk-taking behavior under information technological turbulence? *The Journal of Risk Finance*.
- Schilling. M. A., & Green. E. (2011). Recombinant search and breakthrough idea generation: An analysis of high impact papers in the social sciences. *Research Policy*. 40(10). 1321-1331.
- Siahtiri. V. (2017). Does cooperating with customers support the financial performance of business-to-business professional service firms? *Journal of Service Theory and Practice*.
- Siahtiri. V. (2018). Innovation at the service encounter in knowledge intensive business services: Antecedents and boundary conditions. *Journal of Product Innovation Management*. 35(5). 742-762.
- Siahtiri. V., Heirati. N., & O'Cass. A. (2020). Unlocking solution provision competence in knowledge-intensive business service firms. *Industrial Marketing Management*.
- Srivastava. P., Iyer. K. N., & Rawwas. M. Y. (2017). Performance impact of supply chain partnership strategy-environment co-alignment. *International Journal of Operations & Production Management*.
- Storey. C., & Kahn. K. B. (2010). The role of knowledge management strategies and task knowledge in stimulating service innovation. *Journal of service research*. 13(4). 397-410.
- Storey. C., & Larbig. C. (2018). Absorbing customer knowledge: how customer involvement enables service design success. *Journal of service research*. 21(1). 101-118.
- Su. Z., Peng. J., Shen. H., & Xiao. T. (2013). Technological capability, marketing capability, and firm performance in turbulent conditions. *Management and Organization Review*. 9(1). 115-137.
- Troilo. G., De Luca. L. M., & Atuahene-Gima. K. (2014). More innovation with less? A strategic contingency view of slack resources, information search, and radical innovation. *Journal of Product Innovation Management*. 31(2). 259-277.
- Wentrup. R., & Ström. P. (2019). Service Markets: Digital Business Models and International Expansion *Digital Business Models* (pp. 169-199): Springer.

- Wilden. R.. & Gudergan. S. P. (2015). The impact of dynamic capabilities on operational marketing and technological capabilities: investigating the role of environmental turbulence. *Journal of the Academy of Marketing Science*. 43(2). 181-199.
- Wu. B.. Wan. Z.. & Levinthal. D. A. (2014). Complementary assets as pipes and prisms: Innovation incentives and trajectory choices. *Strategic Management Journal*. 35(9). 1257-1278.
- Zahra. S. A.. Neubaum. D. O.. & Larrañeta. B. (2007). Knowledge sharing and technological capabilities: The moderating role of family involvement. *Journal of Business Research*. 60(10). 1070-1079.
- Zhou. K. Z.. & Wu. F. (2010). Technological capability. strategic flexibility. and product innovation. *Strategic Management Journal*. 31(5). 547-561.

### **Authors' Contribution**

All authors contributed equally to the development of this article.

### **Data availability**

All datasets relevant to this study's findings are fully available within the article.

### **How to cite this article (APA)**

Kerdpitak, C., & Kerdpitak, N. (2026). EFFECT OF DISTAL SEARCH, TECHNOLOGICAL TURBULENCE AND SOLUTION PROVISION COMPETENCE ON SOLUTION PERFORMANCE IN PHARMACEUTICAL SERVICES IN THAILAND. *Veredas Do Direito*, 23(5), e235625. <https://doi.org/10.18623/rvd.v23.5625>